

Quick Setup Guide for the IP Bell v2 door entry phone station

SIP based VoIP video door entry intercom

Access control

- access codes via pushbuttons
- optional integrated RFID reader module (EM Marin / HID)

External IP camera connection

- optional connection of an external IP camera (integrated RFID reader module required)



Opening the cover

- Use a standard screwdriver or you can replace the standard supplied screw by an Allen key screw. Open the cover.
- To change the button labels, look at figures below.

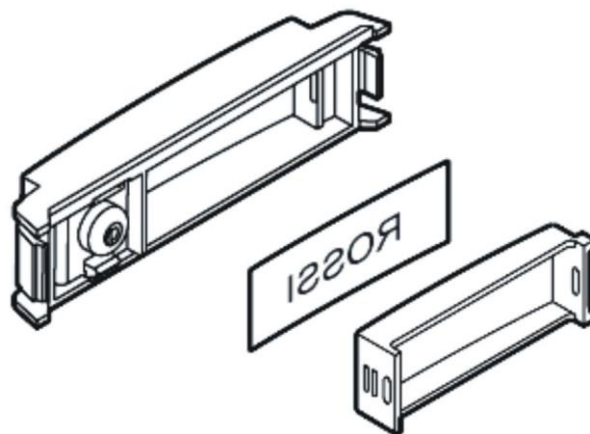
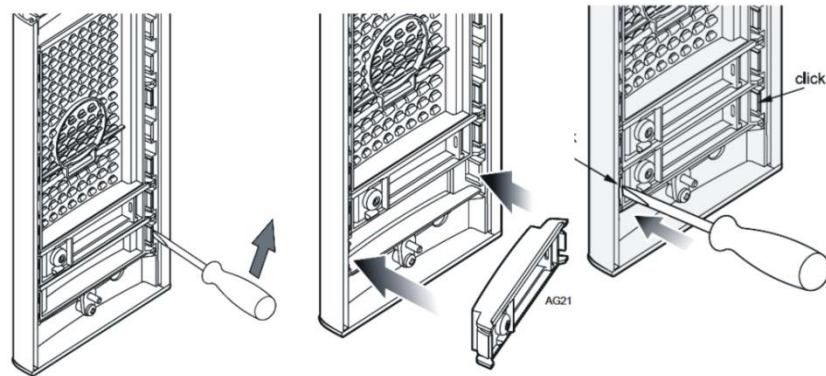
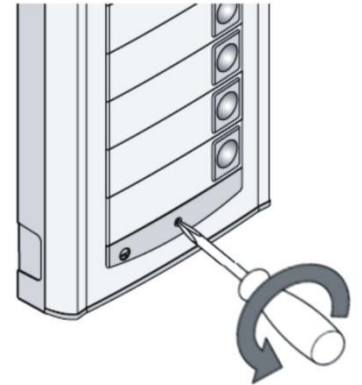

Wiring and mouting on the wall

- Remove the Cover as per above figure.
- Feed the Ethernet cable through the cable hole.
- Fix the door phone to the wall using a template, screws and rawplugs.
- Pay attention to the appropriate installation height as shown on the figures below.

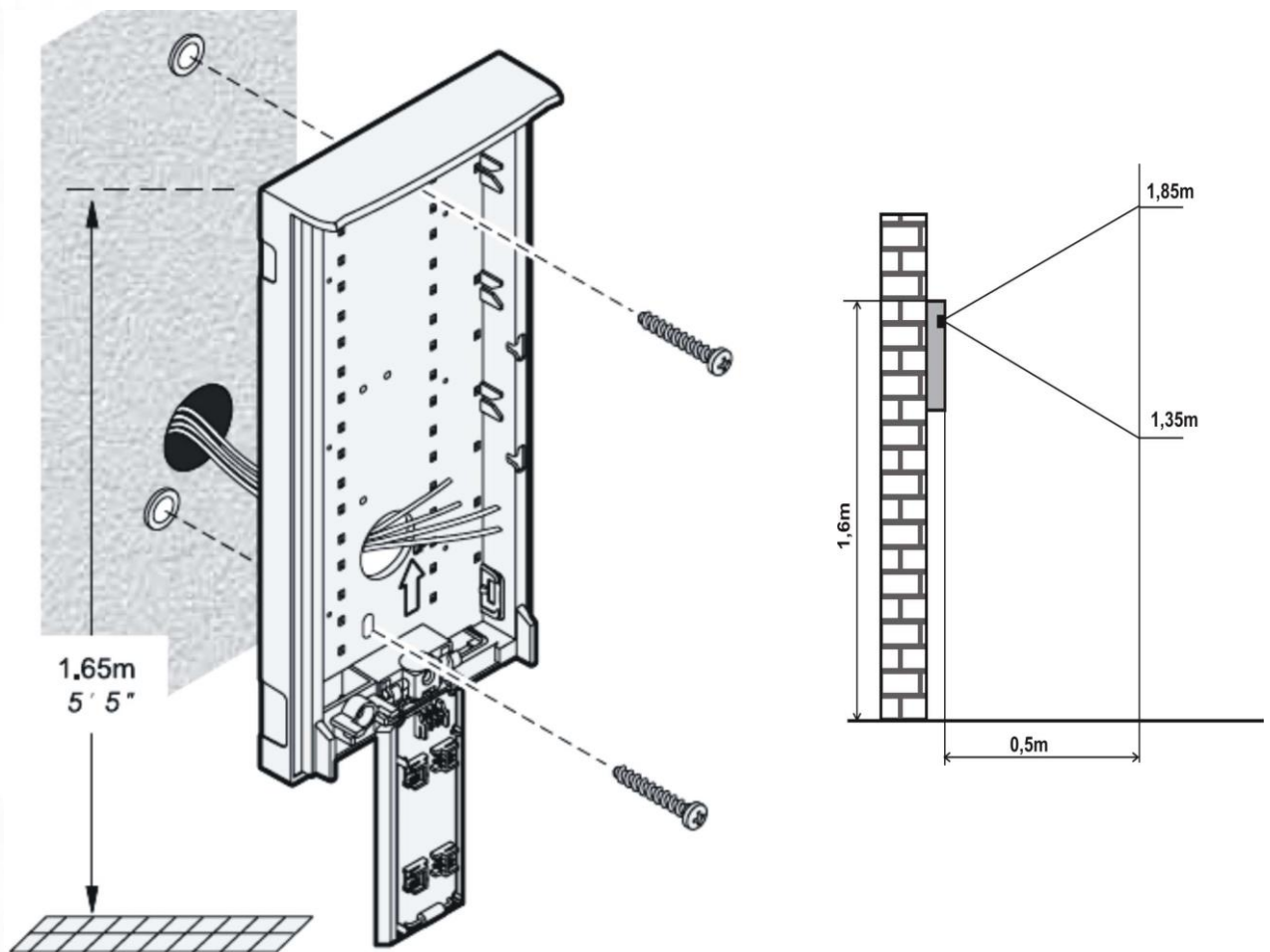

- In order for backlight, heating of the circuit board (to avoid condensation) and to power an electric lock, a 12VDC 1A power supply is required. Refer to the figure below, point 20. Refer to manual.
- There are two options to control external devices e.g. Lock, Light, Bell. Either NO (Normally Open) or NC (Normally Closed). Refer to the figure below, points 14 and 16.

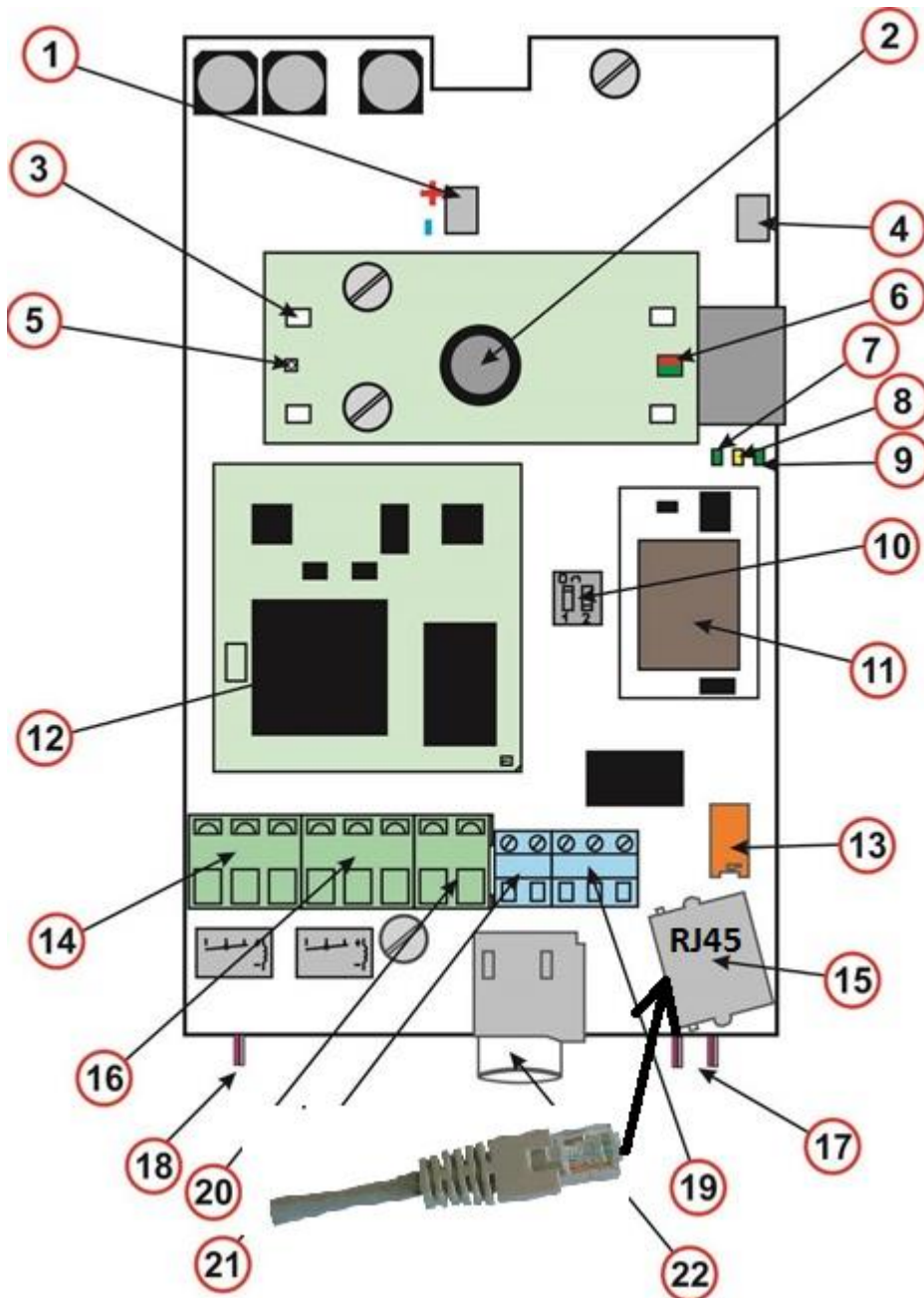

Closing the cover

- Close the front cover as shown on the figure.

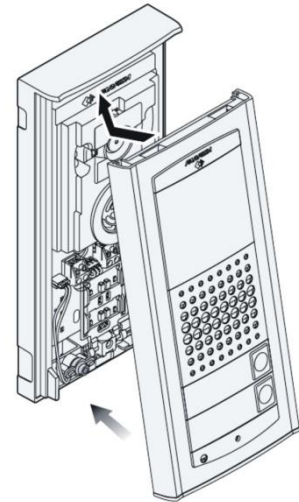

Quick Setup

- The DoorPhone comes with a static IP address of 192.168.1.250 with username: admin and password: 1234

Programming the Door Phone

- Change your PC IP address within the range of 192.168.1.x
- Open your browser and point to 192.168.1.250
- Enter username: admin and password: 1234
- For more advanced options, please refer to the manual.

<http://192.168.1.250/cgi-bin/view.sh>



Stop Play

[Setup](#)

Customer at front door (Door Phone)

When a customer comes to the front door, he presses one of the buttons, the unit then dials the destination number or IP address that is preprogrammed. The staff member answering the call, can talk to the customer at the front door and to let the staff member in the front door, the staff member presses 55 on his handset to open the door.

Authorised staff member at the door (Door Phone)

When an authorised staff member comes to the front door, he can release the electrical lock and open the door by dialling a secret access code via buttons of the doorphone. There can be different access codes for day and night mode. E. g. the secret access code for the day mode is 22121. By dialling 22121 (i. e. by pressing the second button twice, the first button once, the second button once and the first button once), the door lock is released and the staff member can open the door. This feature can be disabled, e.g. during the night mode.

Another option is to use an add-on, integrated RFID module (EM Marin 125kHz / HID). All staff member cards/keyfobs can be administered manually or via PC (RS485/Ethernet coverter is required for PC connection and administration). All events can be stored into SQL db, an external IP camera can be connected, images from the camera can be recorded and stored, etc.

MJPEG video stream of the camera

The doorphone is setup in default to 192.168.1.250. If you have not changed its default IP address, then you can find the video stream at this address: <http://192.168.1.250/video.mjpg>

