

## Quick setup instructions for the 2-Wire-LAN system

version B with an extra B „Boost“ port for up to 1Gbps transmission speed over 3 wires

- Review the contents for any damages. When in doubt, don't use the devices.
- Do a dry run first: Take out the two (or more) 2-Wire LAN devices, the 48VDC power supply, the primary power connector, a short pair of power wires, and a small screwdriver.

### *Installation*

- Connect the green connector with a pair of power wires. Make sure that plus and minus are not switched. There is no correct plus and minus for this. It's more important not to cross the wires when connecting them.
- Plug both connectors into the two 2-Wire-LAN devices.
- Connect the power supply unit with one of the two devices.
- Now connect the main power connector with the power supply adapter and the power.

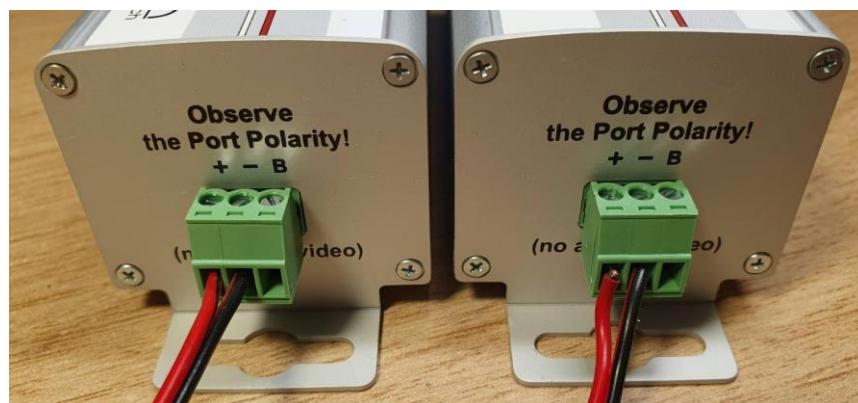
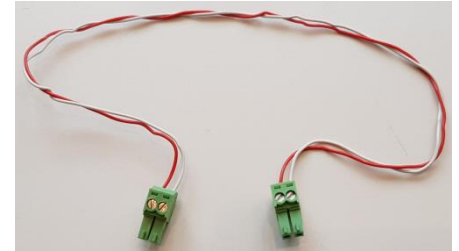

If you use the B port for the “Boost” function, this means in case you use the 3<sup>rd</sup> wire for increasing the data transmission up to 1,000Mbps, make sure you do not cross the wires with + or – ports. See the image below.



If you have more wires available, follow the wiring drawing below, always pay attention to the correct polarity and do not cross or change the wires in any of the 2-Wire-LAN devices. It is true that more used wires improve the data throughput. CAT5E, CAT6, J-Y ST (Y) 2x2x0.6, etc. cables can be used. Actual data throughput varies depending on cable length, cable specification and cable conditions.

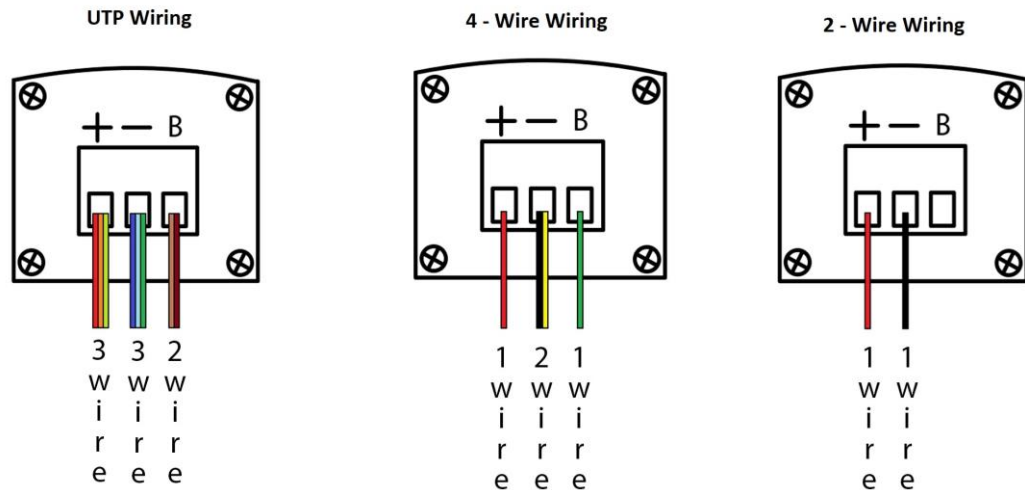

**It is important to plug the power to the 2-Wire-LAN system as the last**  
**When the power is plugged on, the devices are in automatic coupling mode and don't need to be explicitly coupled!**

- As soon as the power LED and TWP LED of both devices start flashing, the two devices are connected.
- You can now connect two devices to the LAN interfaces for testing. This could be a switch or your router on the one hand, or a laptop or other LAN device on the other hand. Since the system also supplies PoE power according to IEEE 802.3af/at, the connected device could also, for example, be an IP camera, an IP phone, or an IP intercom. The lighting of the PoE LED shows that a LAN device is connected. The blinking/flushing of the Power, PoE and TWP LEDs shows that the system is in operation and the data is flowing.



Both devices connected with each other.

Both devices connected with LAN. Data is flowing.

- To connect a third (or additional) device (that hasn't been in operation yet), disconnect the power from the power supply unit
- Remove the green connector of one of the two devices
- Plug the green connector into the third (or additional) device
- Plug-in the power of the power supply adapter again
- The third (or additional) device is now also connected
- Attention. Never connect Ethernet cables intended for converters to switch ports with PoE power. Do not connect the PoE ports of the switch to any converter. Otherwise, you will irreversibly damage the converters.



You are now ready to complete the actual installation in your space.

**Description of the LED lights:**

Power LED: The power LED slowly flashes blue - the activity of the main chip is OK.

TWP LED: Flashes green when data transfer is over 40Mbps, red-green when the speed is between 20-40Mbps, red when the speed is lower than 20Mbps.

PoE LED: flashing red-green. Green color indicates Ethernet activity. The red color has no meaning during operation, only during pairing and reset of the converters.

*Decouple Devices*

Devices may lose their configuration. This happens when the devices are connected too long with switched plus/minus connections or when contact is faulty for an extended, sustained period of time. You might also remove a device from the connection configuration in order to set up a new configuration.

- Connect the desired device to the 48VDC power supply adapter and connect this to the power
- Press the Grp button (with a paper clip) for twelve seconds
- Release it: You will notice that all LEDs go out and then come on again. If this isn't the case, you didn't hold it down long enough
- Disconnect the device from the power

*Couple Devices*

- Connect one of the existing devices with this decoupled device
- Now connect one of the two with the power supply unit and power
- Hold down the Grp button of the decoupled device for three seconds
- Hold down the Grp button of the existing device for three seconds
- Both devices are now in coupling mode. After about ten seconds, they will have "found" each other. If the TWP LEDs of both devices are lit up, this means the coupling was successful.

Below you can find a few examples of how the connection can be made. A mixture of these can be used as long as no more than five devices are connected with each other.

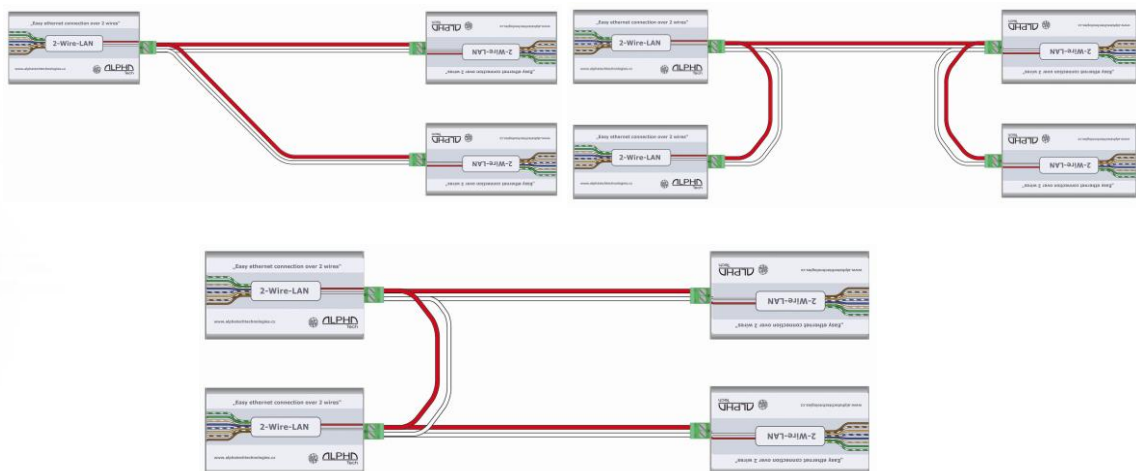

The 2-Wire-LAN 1Gbps converter has an integrated 1.5A resettable fuse to protect it against a short circuit. However we do not recommend any installation where a short circuit might occur. In case of a short cut, the product is out of warranty.

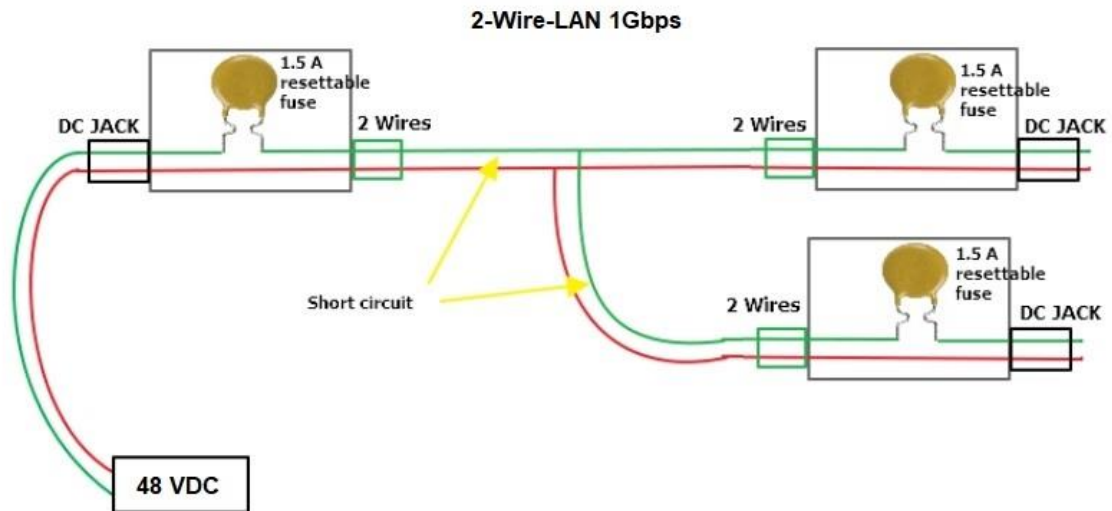

**IMPORTANT:** it doesn't matter where the power is fed in. Simply connect the power supply adapter to any one of the existing 2-Wire-LAN devices and the others will automatically be supplied. This will generally be the case for the device that is installed at the start. It isn't absolutely necessary though.



A typical scenario of the 2-Wire-LAN system with an extra B „Boost“ port for up to 1,000Mbps data transmission over the 3-wire or more wires connection. Actual data throughput varies depending on cable length, cable specification and cable conditions.

